

# Pipeline Explorer Challenge

## Pipeline Explorer Challenge

In this challenge, your robot must enter a damaged pipeline, locate the damaged section, apply a patch, return to the surface, and report the location of the damage.

### Materials

- 4' long light-colored smooth playing surface, at least 1' wide (hard floor, table, shelf, panel)
- Cardboard boxes to form a "tunnel" over the game area
- Black removable tape to mark damaged area
- A bracelet or similar object to represent the pipe "patch", an expanding metal ring that blocks leaks from the inside of the pipe

### Playing Field Setup

1. Use part of a standard 4'x4' gameboard or floor space
2. Using the board diagram below:
  - a. **Start Line**: Make one dark tape line just inside the pipe
  - b. **Goal Line ("Damaged Area")**: Make a second dark tape line to mark the damaged area
3. **"Pipe"**: Cover the entire length of the game board with a tunnel constructed of empty cardboard boxes. You may need to cut or partially disassemble the boxes so side flaps don't block the robot's passage inside the "pipe".
4. Complete the challenge as described in the Rules and Procedure section on the next page!

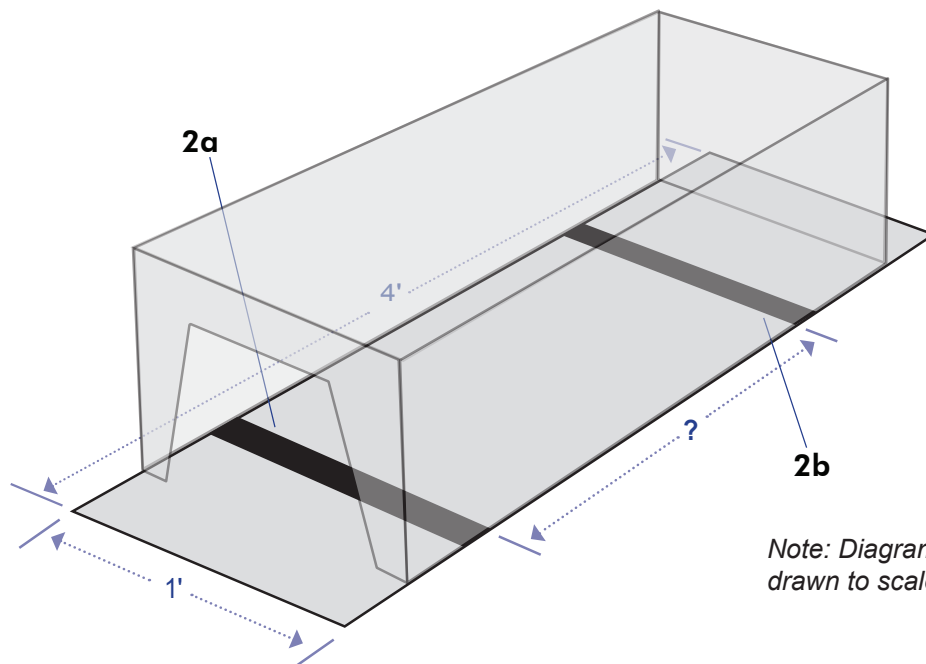

*Note: Diagrams are not drawn to scale*

# Pipeline Explorer Challenge

## Rules and Procedure

Like real-world engineering projects, this challenge builds on past programs to achieve new results.

1. Start with the robot in hand
2. Run the program on the robot
3. Using simple button presses, record the Dark and Light values inside the tunnel
  - **Hint:** On-screen written instructions can tell you which reading the robot is waiting for
  - Base this behavior on the **Automatic Threshold** project in the Logic section
4. Automatically calculate the threshold for the inside of the tunnel
5. Place the robot on or behind the starting line (your choice)
6. Load the reinforcing band into/onto your robot (depending on your design)
7. Signal the robot to begin its run into the pipe
  - You may not run a separate program for this step
  - **Hint:** Again, on-screen reminders may be helpful
8. The robot must travel to the damaged area (second tape line)...
9. ... deploy the reinforcing band (drop it on the line) ...
- 10.... then return to the start line.
11. The robot must then display (on its screen) the distance between the Start Line and the Goal Line, in centimeters
  - For this challenge, the distance to be measured is only the “light” area between the two dark lines – do NOT count the thickness of the black line itself
  - Base this behavior on the “Line Measurer 2” project in the Calculations section
12. Move the Goal Line, and run your program again
13. Beat the challenge by:
  - a. Successfully reporting the correct distance both times, within 5% of the actual distance
  - b. Successfully leaving the “patch” ring in a position touching the Goal Line both times